



# TOMRA R2



REVOLUTION LINE



## Rethink recycling



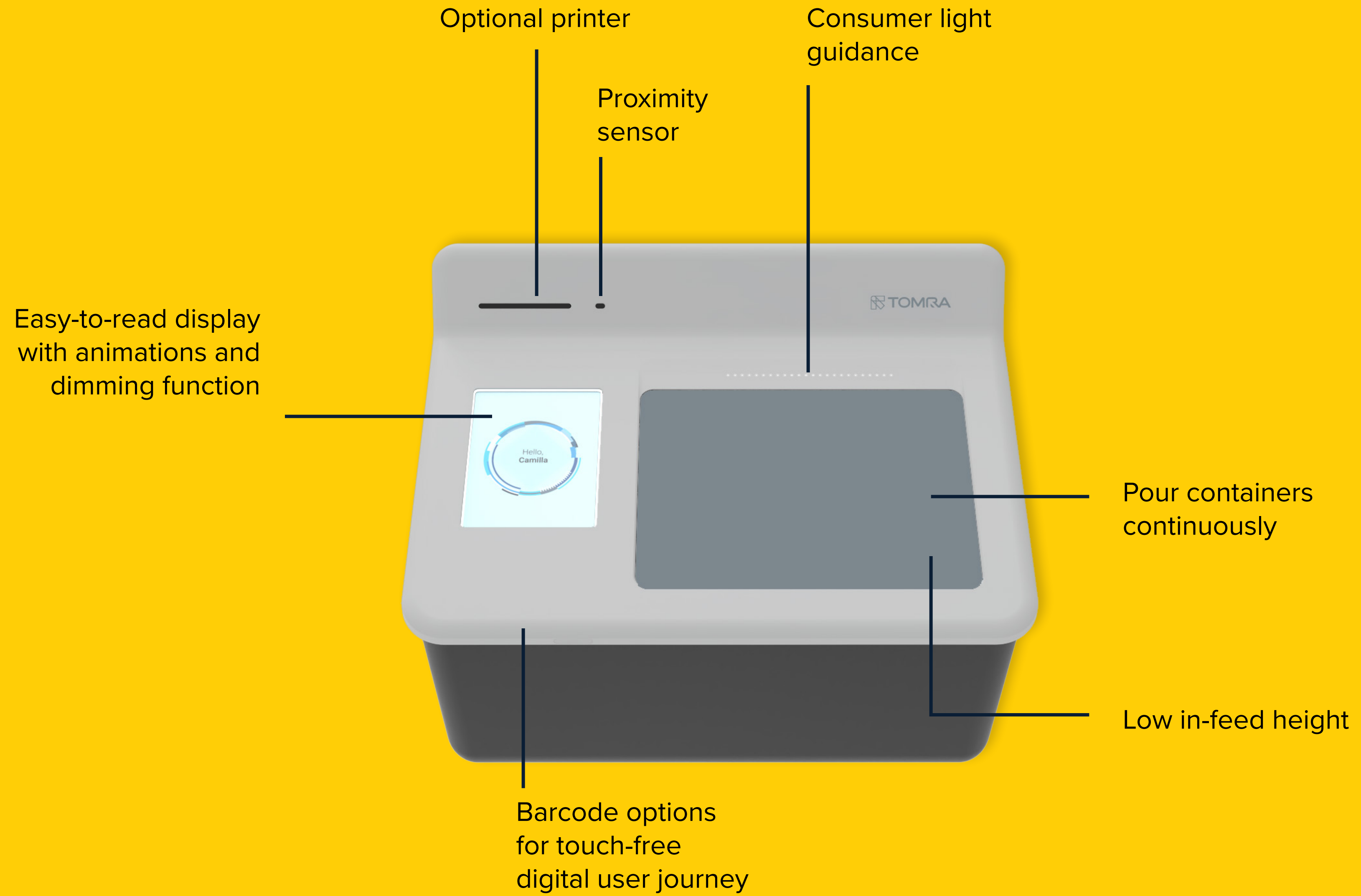

## Bring the big benefits of multi-feed container returns to your store

Experience increased visits and improved customer satisfaction\* with the new TOMRA R2 multi-feed solution. Its wall-mount format and compact design require less space, giving you more sales space, and bringing the ultimate recycling experience to even more stores.



## Designed with people in mind

TOMRA R2 was designed with inclusivity in mind. With a lower in-feed and screen, plus illuminated user guidance, every aspect is crafted to accommodate users of various abilities\*\*, ensuring that your customers can participate in recycling efforts without barriers.



## Grab customers' attention and increase loyalty

The TOMRA R2 makes recycling feel effortless. There's no mess and no sticky hands – just fast, simple, and convenient. Customers can pour all their containers in at once – bag after bag. With the new drop-and-go function, they can walk away while the machine does the rest and get back to shopping quicker. A great all-around recycling experience like this keeps customers coming back\*.



## Optimize operations with efficiency and ease

Perform tasks undisturbed and save time and effort. Clean, maintain, and troubleshoot the machine directly from the backroom – no need to walk back and forth to the front. Plus, pair your TOMRA R2 with TOMRA's digital tools for the most convenient way to stay one step ahead of recycling management.

\* "TOMRA R1 Consumer & Retailer insights", 2021 and "How recycling habits impact shopping behavior", 2023.

\*\* Usability testing: wheelchair users, visual impairment, individuals with ASD.

## Layout flexibility

Pair the TOMRA R2 with your existing TOMRA solutions for a smart futureproof investment. Reuse your existing TOMRA backroom solution and end-of-lane configuration kit. Install it side-by-side with your existing TOMRA single-feed solution.

TOMRA R2 system layout options:

TOMRA R2 main and front unit

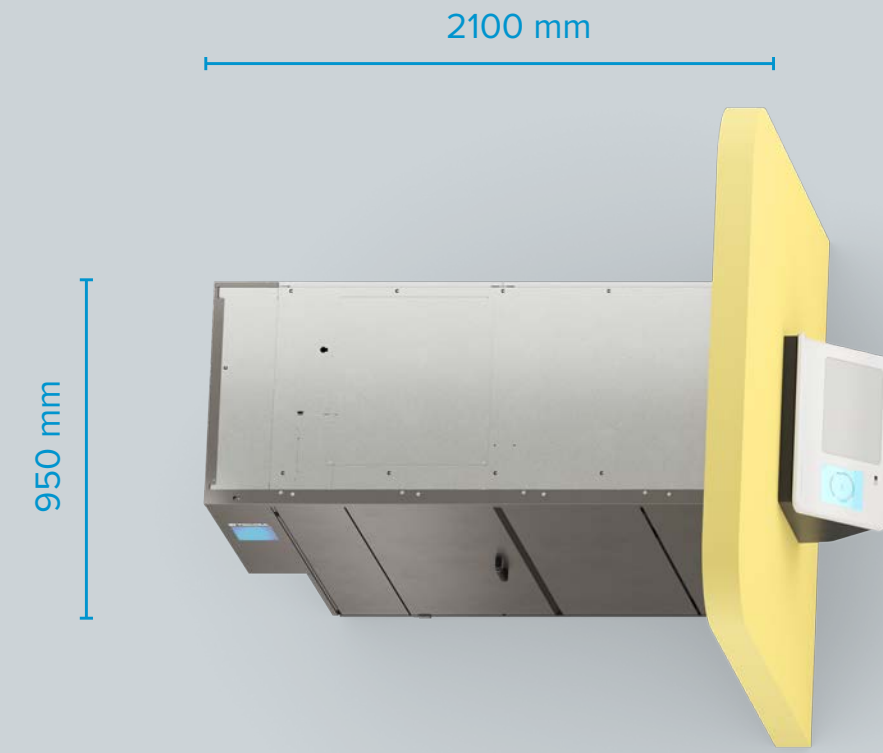

TOMRA R2 with 2x RollPac left-side bin emptying and SoftDrop

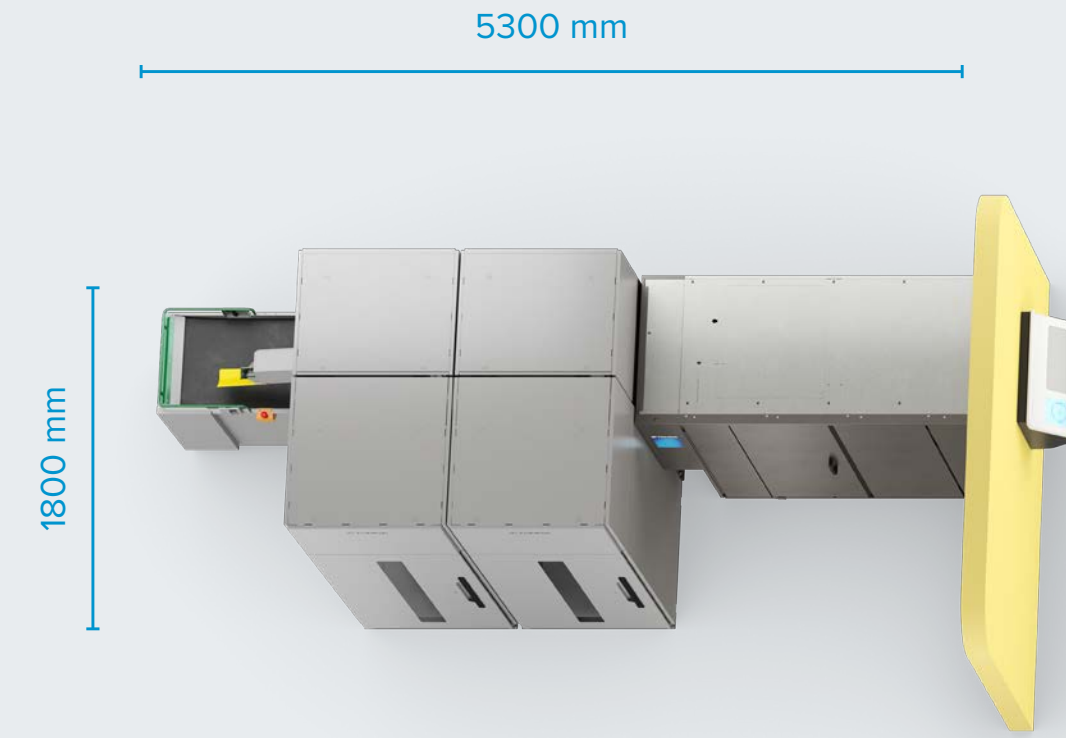

TOMRA R2+T9 with 2x MultiPac left-side bin emptying

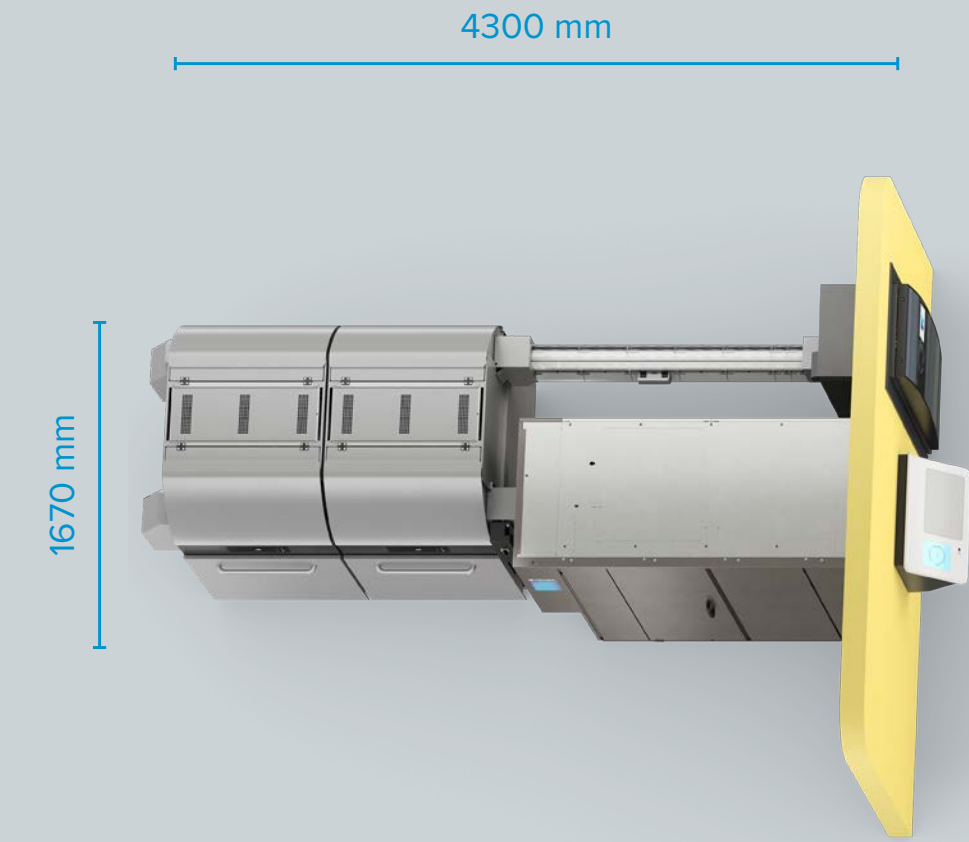

TOMRA R2+T9 with MultiPac, bottle raiser table, crate line and SoftDrop

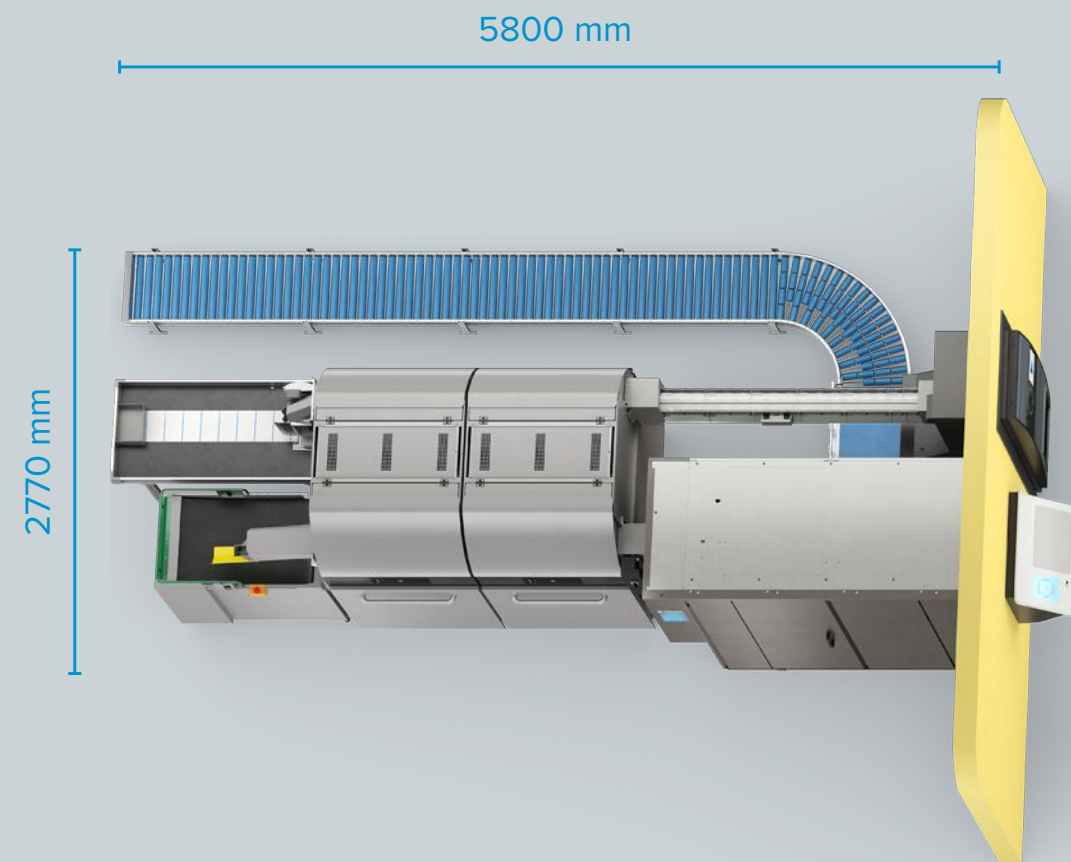

TOMRA R2+T9 with MultiPac, bottle raiser table, crossing crate line and SoftDrop

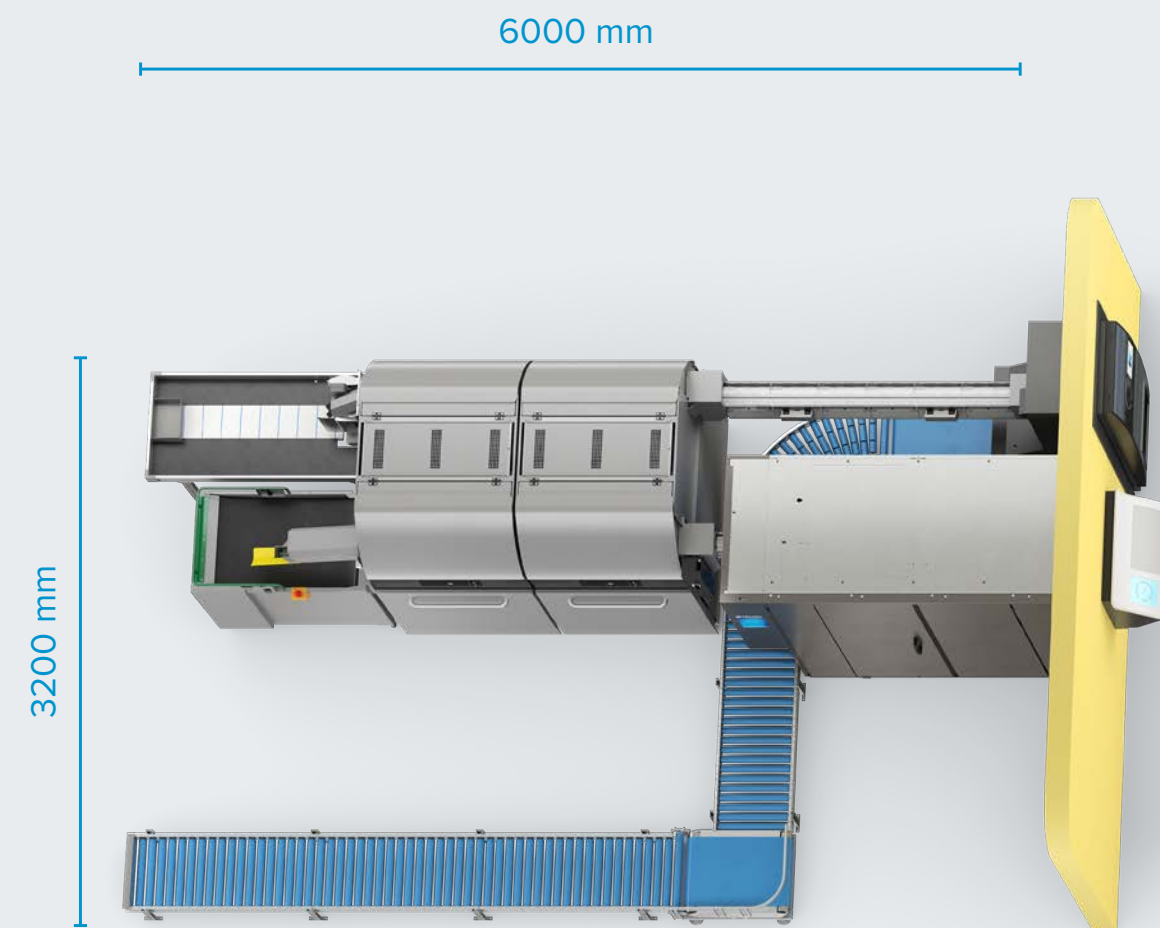

TOMRA R2 with 2x EasyPac Pro ALONG cabinets, left-side bin emptying

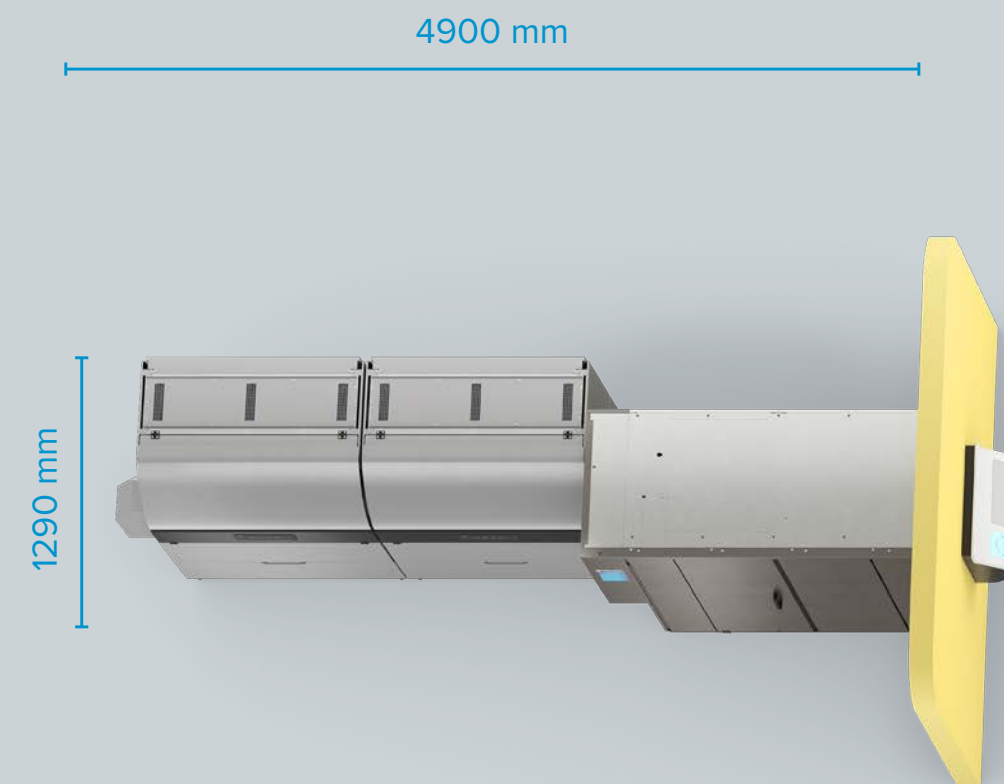

TOMRA R2 with 2x EasyPac Pro ACROSS cabinets, left-side bin emptying

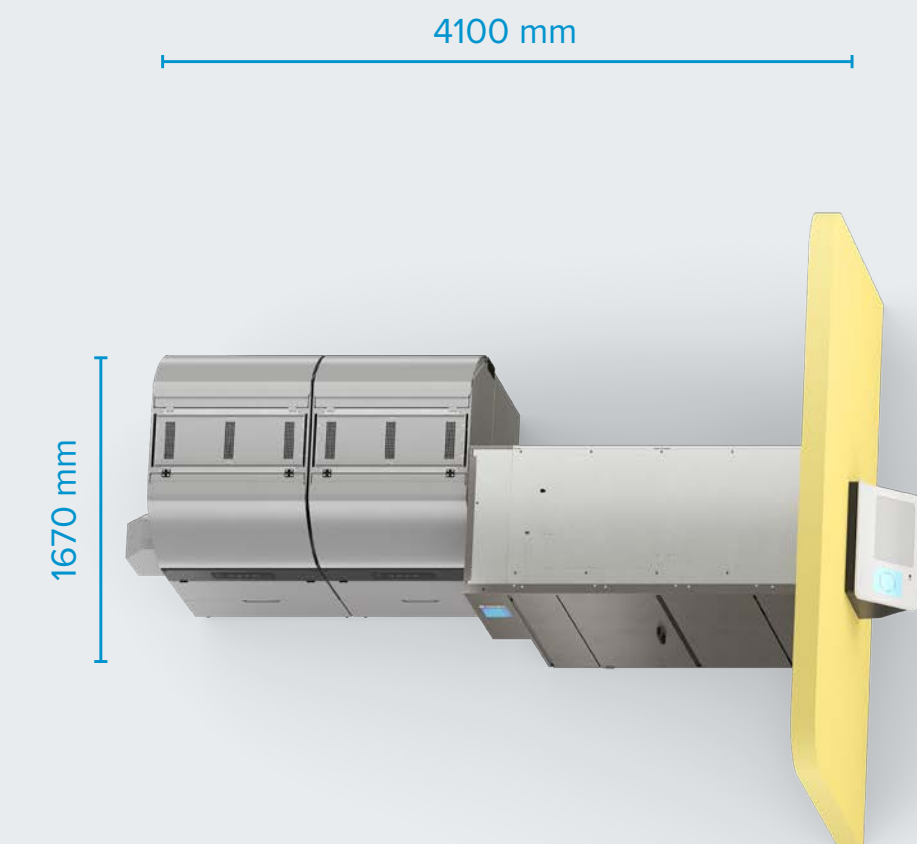

# TOMRA R2 backroom compatibility

with TOMRA MultiPac



with TOMRA EasyPac Pro ALONG



with TOMRA EasyPac Pro ACROSS



with TOMRA RollPac



## Retailers help the world recycle

Deposit return systems (DRS) for beverage container recycling help keep valuable resources in a continuous loop of use and reuse. At TOMRA, we call this process Clean Loop Recycling.

As a retailer, you're at the heart of Clean Loop Recycling. You play a critical role at the point where consumers buy and return their containers.



Let's put recycling to work for you

Choosing to partner with TOMRA means creating a **great recycling experience for your customers**, making a **smart investment for your store**, and choosing a solution that brings **peace of mind and excellent support for your operations**.

# TOMRA R2™

Rethink recycling

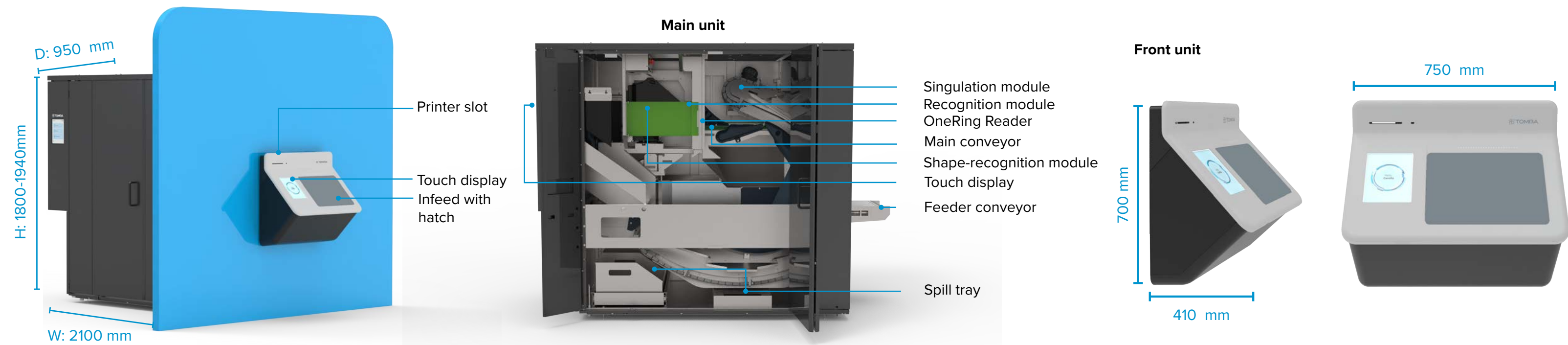

TOMRA R2/ENG/11.2025

## MEASUREMENTS

<b>Dimensions</b> [W x D x H]	Main unit: 950 mm x 2100 mm x 1800-1940 mm Front unit: 750 mm x 410 mm x 700 mm
<b>Infeed height</b>	855-995 mm
<b>Adjustment range for height</b>	140 mm
<b>Footprint</b>	2.00 sqm main unit (behind the wall)
<b>Weight</b>	19 kg front unit, 473 kg main unit, 492 kg complete unit

## STANDARD CONFIGURATION

<b>Machine type</b>	Wall-mounted consumer facing reverse vending machine
<b>Colors</b>	Dark grey
<b>User interface</b>	<b>Consumer-facing display:</b> 10.4" touch display, video and sound capabilities, user guidance on machine screen <b>Operator display:</b> 10.4" touch display, video and sound capabilities, user guidance on machine screen <b>Printer:</b> Thermal printer
<b>Optional configurations</b>	Loyalty reader
<b>Compatible backroom products</b>	TOMRA MultiPac, EasyPac Pro, RollPac and end-of-lane configuration kits

## RECOGNITION

<b>Recognition technology</b>	TOMRA Flow Technology™ (360° instant recognition, shape recognition, full container detection, barcode recognition, and metal detection)
<b>Accepted containers</b>	Cans, reusable and non-reusable glass and plastic bottles.
<b>Speed capability</b>	Up to 100 containers per minute <sup>1</sup>
<b>Container sizes</b>	Bottle size: Diameter 50-130 mm, height 85-380 mm Can size: Diameter 50-100 mm, height 80-200 mm
<b>Optional features</b>	Security mark recognition (market specific)

## ENVIRONMENTAL

<b>Humidity</b>	Maximum 90% relative humidity, non-condensing
<b>Temperature</b>	+10°C to +40°C / +50°F to 104°F
<b>Noise</b>	The machine has been designed for indoor use Noise Equivalent Continuous Sound Pressure: <b>Front unit</b> (in store with lid closed): <b>Can:</b> 70,6 dBA, <b>Mix:</b> 64,4 dBA <sup>2</sup> <b>Main unit</b> (behind wall): <b>Can:</b> 85,4 dBA, <b>Mix:</b> 78,6 dBA <sup>2</sup>

## STORAGE CAPACITY

<b>Accepted containers</b>	3 types of containers: Cans, plastic and glass bottles
<b>Storage capacity per bin</b>	<b>PET bottles (compacted):</b> Up to 1500 (TOMRA MultiPac and TOMRA EasyPac) and up to 2200 (TOMRA RollPac) <sup>3</sup> <b>Cans (compacted):</b> Up to 6000 (TOMRA MultiPac and TOMRA EasyPac) and up to 8000 (TOMRA RollPac) <sup>3</sup> <b>50/50 mixed PET bottles/cans (compacted using mix crusher):</b> Up to 2000 (TOMRA MultiPac and TOMRA EasyPac) and up to 3000 (TOMRA RollPac) <sup>3</sup> <b>Glass bottles:</b> Up to 400 (TOMRA MultiPac and TOMRA EasyPac) <sup>4</sup> Table option also available – capacity depending on size.

## ELECTRICAL

<b>Power consumption</b>	Idle 0,08 kW, max. 0,55kW
<b>Mains</b>	TOMRA R2 with TOMRA EasyPac or TOMRA RollPac (Europe): 400 V AC, 3-phase w/ground, 50 Hz, 16 A fuse TOMRA R2 with TOMRA MultiPac 2 (Europe): 230 V AC, 1-phase w/ground, 50 Hz, 16 A fuse

## CONNECTIVITY

<b>External IT interface</b>	LAN (Ethernet TCP/IP), POS compatible
<b>Digital tools</b>	Fully compatible with TOMRA's portfolio of digital products and APIs

- 1 Performance data and system speed may vary across markets, deposit regulations, system requirements and type of backroom cabinet.
- 2 All values with a measurement inaccuracy of ± 4 dBA.  
Can: 100 % cans. Mix: 59 % PET, 29 % can and 12 % glass.
- 3 May vary in different countries due to variations in beverage container materials, shapes and sizes.
- 4 The machine can be configured to allow or restrict glass acceptance.



Get in the Loop at [tomra.com/reverse-vending](https://tomra.com/reverse-vending)

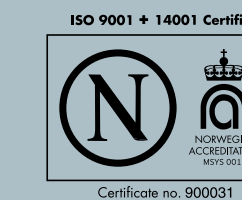

**TOMRA CERTIFICATION**  
TOMRA SYSTEMS ASA has implemented and maintains a Quality and Environmental Management System which fulfils Nemko's provisions for Management System Certification and the requirements of standards NS-EN ISO 9001:2015 and NS-EN ISO 14001:2015, with the scope described by the organization on 2018-05-29. The certification covers the development and delivery of automated systems for recycling.



**LEGAL COMPLIANCE**  
This product is a configurable system of machine components. When assembled on installation site, tested and connected to the grid, the installation must be labelled and have the CE mark affixed. The CE marking is based on the following European Directives:  
2006/42/EU, Community Legislation on Machinery.  
2014/30/EU, Electromagnetic Compatibility (EMC).  
2011/65/EU, Restrictions of Hazardous Substance (RoHS).  
2012/19/EU, Waste Electrical and Electronic Equipment (WEEE).

We reserve the right to make changes to specifications without prior notice. While every effort has been made to ensure all information contained in this document is accurate, TOMRA assumes no liability for any errors, inaccuracies or omissions that may occur. All products and offers are subject to country availability. Please consider the environment before printing.

## TOMRA Collection

TOMRA Collection is part of the TOMRA Group, which is Leading the Resource Revolution by transforming how we obtain, use, and reuse our world's resources.

With installations across the world, retailers and consumers rely on our reverse vending machines to collect used bottles and cans that can be recycled into new containers.

Clean Loop Recycling is the easy and rewarding way to make choices that make change.

Get in the Loop at  
[tomra.com/reverse-vending](https://tomra.com/reverse-vending)

